

Sherpa Style Kit

Instructions for:

Sherpa Style Wrap or Sherpa Throw or Sherpa Pocket Scarf and Hat

Read all instructions before beginning project.

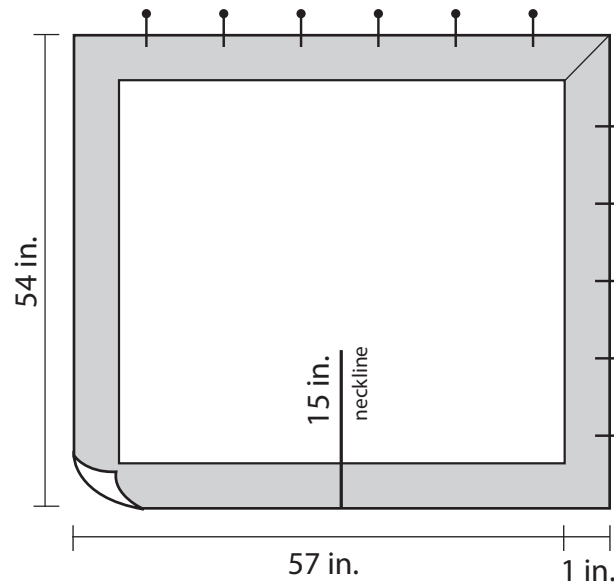
Use 1/2" seam allowance unless otherwise noted.

Sherpa Style Wrap (see diagram A)

1. Using the entire piece of Sherpa Suede 54" x 57" mark the center on one of the 57" sides.
2. Cut a line 15" in from the center mark; this will be the neckline slit.
3. To finish raw edges begin at the neckline slit, turn and pin the Sherpa edge onto the suede side 1" along all four sides.
4. Using the widest and longest zigzag stitch, beginning at the 15" neckline slit, sew 1/4" from the raw edge around all four sides.



Diagram A

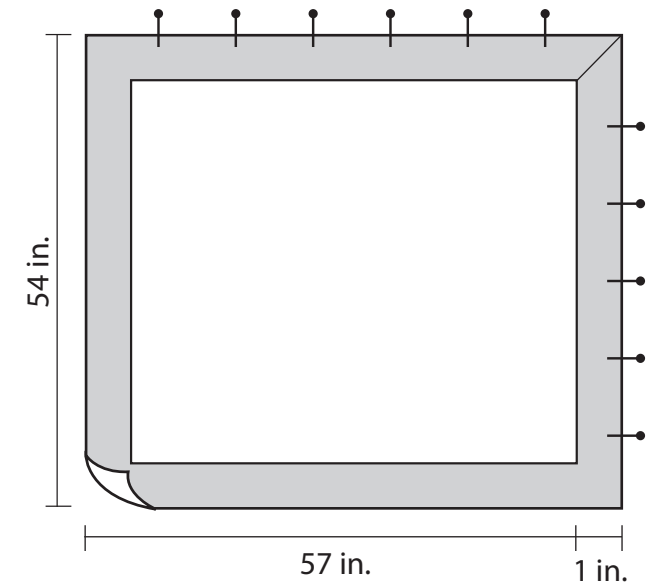


Sherpa Throw (see diagram B)

1. To finish raw edges use the entire piece of Sherpa Suede 54" x 57", turn and pin the Sherpa edge onto the suede side 1" along all four sides.
2. Using the widest and longest zigzag stitch sew 1/4" from the raw edge around all four sides.



Diagram B



Sherpa Pocket Scarf (see diagram C)

Cutting Instructions: (C1)

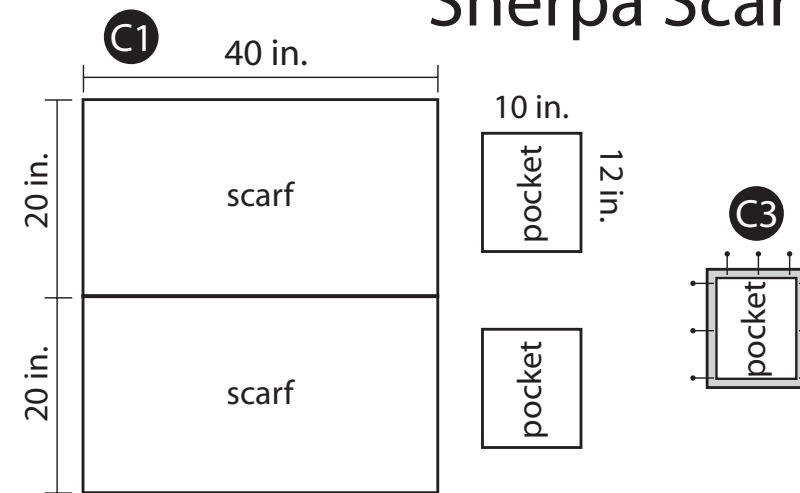
1. Cut two pieces measuring 20" x 40" for the scarf.
2. Cut two pieces 10" x 12" for pockets.

Assembly Instructions:

1. With Sherpa sides together pin the scarf pieces together along one 20" side.
2. Sew the pieces together using a 1/2" seam and the longest straight stitch possible to create a scarf measuring 20" x 79". (C2)
3. Topstitch the center back Sherpa seam allowance down onto the suede using the widest and longest zigzag stitch possible. (C2)
4. To finish the raw edges on the scarf 20" x 79" turn and pin the Sherpa edge onto the suede side 1" along all four sides. Using the widest and longest zigzag stitch sew 1/4" from the raw edge around all four sides. (C2)
5. To finish the raw edges on both pockets 10" x 12" turn and pin the Sherpa edge onto the suede side 1" along all four sides. Using the widest and longest zigzag stitch; sew 1/4" from the raw edge around all four sides. (C3)
6. Center and pin the pockets on the scarf piece as shown in the diagram. Stitch using the longest straight stitch possible around the three sides of each pocket shown on the diagram. (C4)

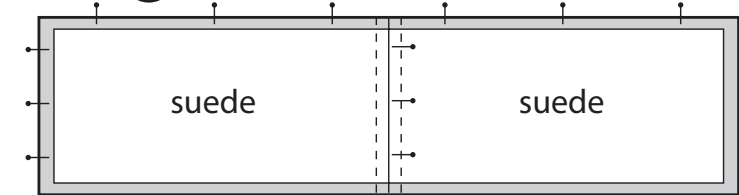


Diagram C

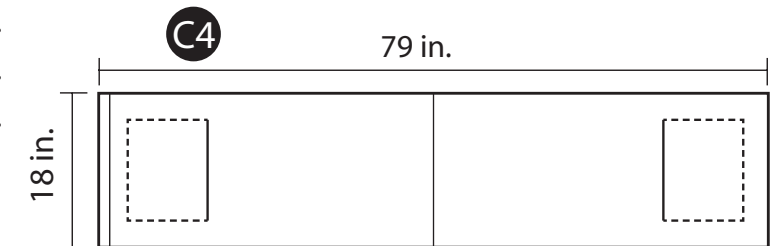


Sherpa Scarf

C2



C4



Sherpa Hat (see diagram D)

Cutting Instructions: (D1)

1. Trace the pattern for the hat crown and hat brim onto a separate piece of paper (not included).
2. Cut one hat crown using pattern.
3. Cut one hat brim on fold using pattern.
4. Cut one hat band 23 1/2" x 4 1/2"

Assembly Instructions:

1. Pin the hat band suede sides together along the 4 1/2" sides. Sew using the longest straight stitch possible and 1/2" seam allowance. Trim seams down to scant 1/4". (D2)
2. Pin the hat crown to the hat band with the suede sides together. Sew using the longest straight stitch possible and 1/2" seam allowance. Trim seams down to scant 1/4". (D3)
3. Sew hat brim with suede sides together at center back seam using longest possible straight stitch and 1/2" seam allowance. Trim seams down to scant 1/4".
4. Pin the hat brim to the hat band suede sides together matching the center back seams on the hat band and brim. (D4)
5. Sew the hat brim to the hat band using the longest stitch possible and 1/2" seam allowance. Trim seams down to scant 1/4".
6. To finish the raw edge, turn and pin the Sherpa edge of hat brim 1/2" onto the suede side.
7. Topstitch 1/4" from the raw edge using the widest and longest stitch possible around the hat brim.

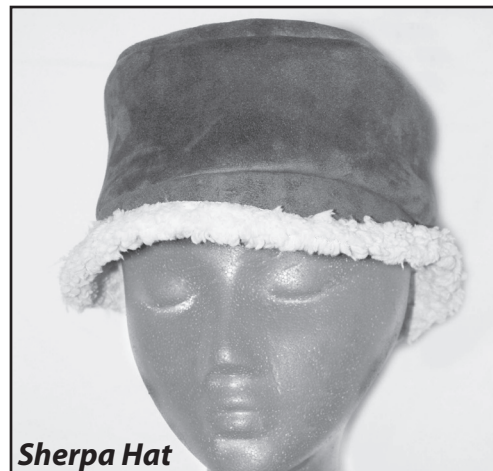
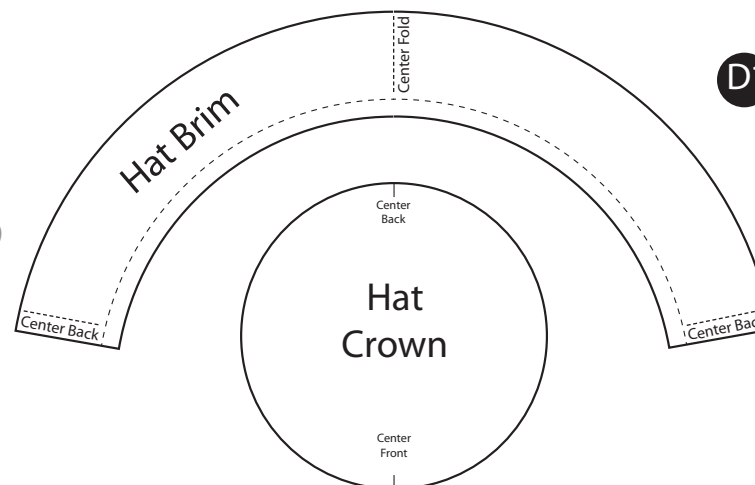
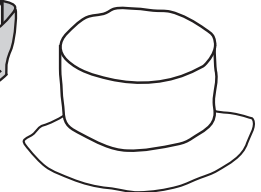
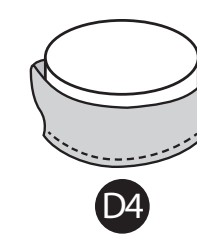
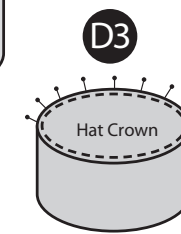
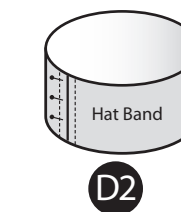
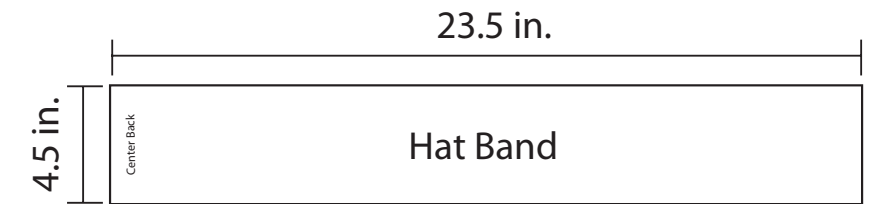
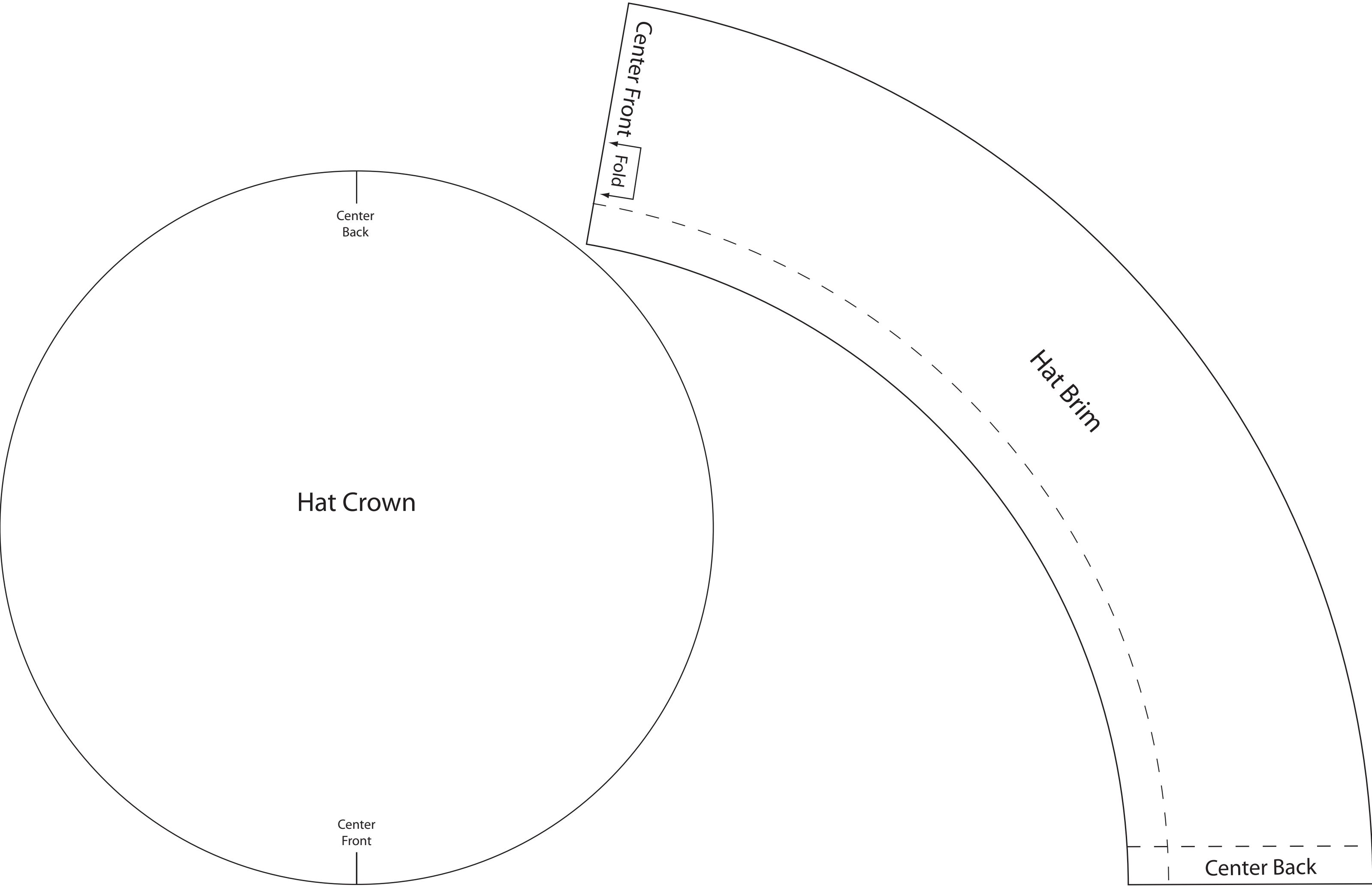


Diagram D



Sherpa Hat





Hat Crown

Center
Back

Center
Front

Center
Front
Fold

Hat Brim

Center
Back