

Everyday Tote

Read all instructions before you begin
 Use long stitch length with quilted fabric
 Use 1/2" seam allowance
 Use pattern layout as your guide.

Cutting Instructions:

Cut two handles 4" x 30" from quilted fabric
 Cut one bag 17" x 32" from quilted fabric
 Cut four trim bands 5 1/2" x 17" from non quilted fabric

Tote Instructions:

- 1: Use a pencil to lightly mark a line lengthwise down the center of each handle on the wrong side of the fabric. Fold raw edges of the fabric in to meet the center line, press. Fold the handle half lengthwise enclosing the raw edges, pin in place and press. Topstitch handle 1/4" from the edge along both lengths of the handle. Set aside. Repeat for second handle. See D1.
- 2: Place bag 17" x 32" flat with right side (dot fabric) facing up. Place 1 band right side (zebra stripe) facing up along the top edge and pin in place. Place one strap on top of band making sure the strap is not twisted and lays flat; pin in place. See D2.
- 3: Place another band wrong side up on top of the strap matching the first band; pin in place. Stitch 1/2" from the top edge, trim seam allowance to 1/4". See D3.
- 4: Fold the top band under to the wrong side (zebra stripe) of the bag, press along the top edge. Turn raw edge on both bands under 1/2", press and pin in place through all layers. Topstitch along the bottom and the top of the band. See D4. Repeat from step 2 on the opposite side of the bag.
- 5: Fold bag in half matching side seams and handles with wrong sides together (zebra stripe). Stitch down both side seams trim seam allowance to 1/4". See D5.
- 6: Turn bag inside out and press side seams flat. Pin side seams and stitch 1/2" seams down both sides to enclose the raw edges. See D6.
- 7: With bag still turned inside out, stitch across the corners of the bag bottom. See D7.

Turn bag right side out and enjoy.

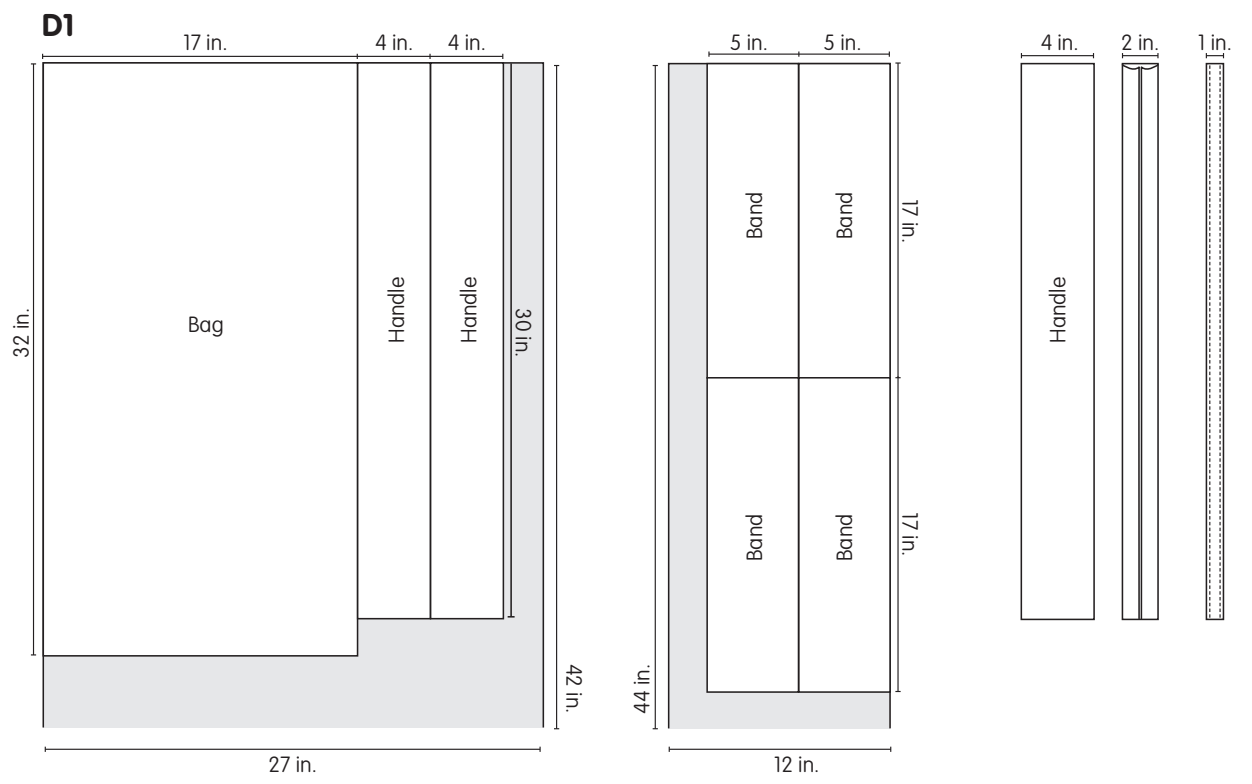

D2

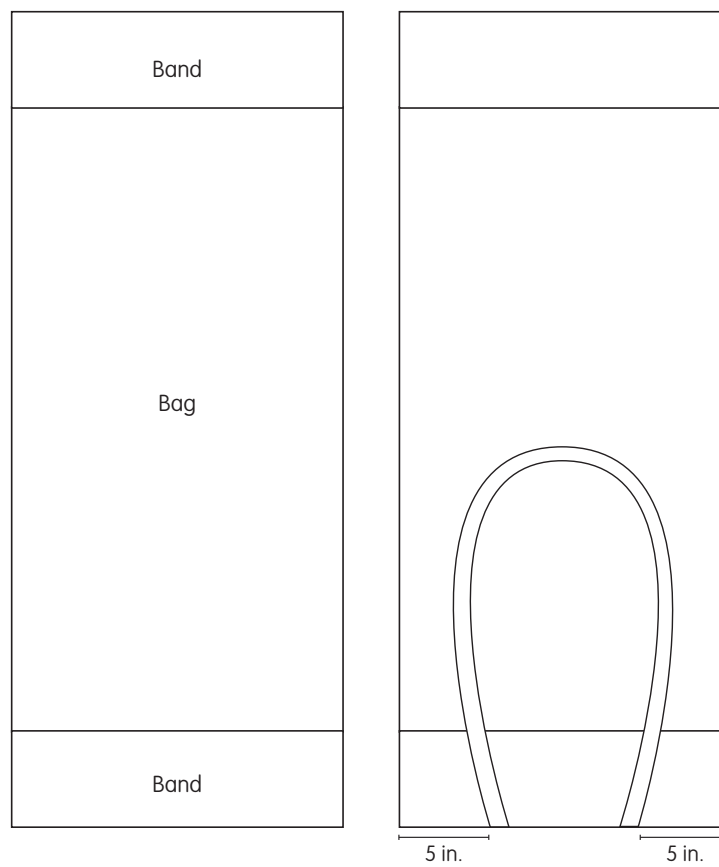

D3

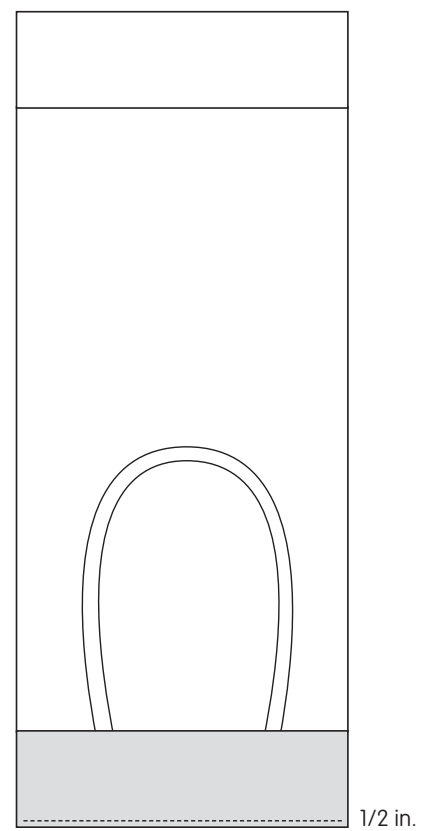

D4

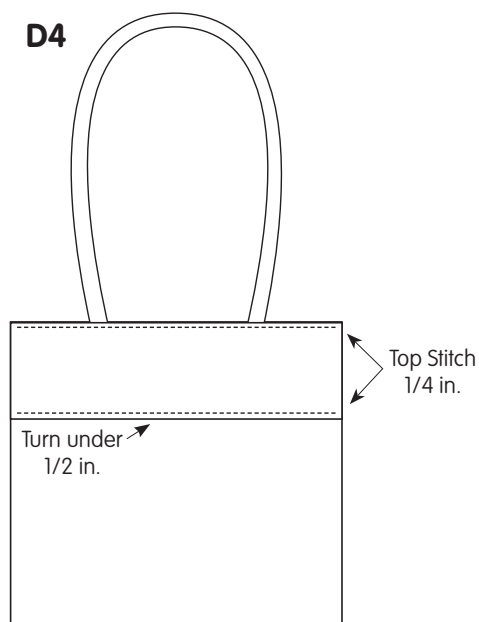

D5

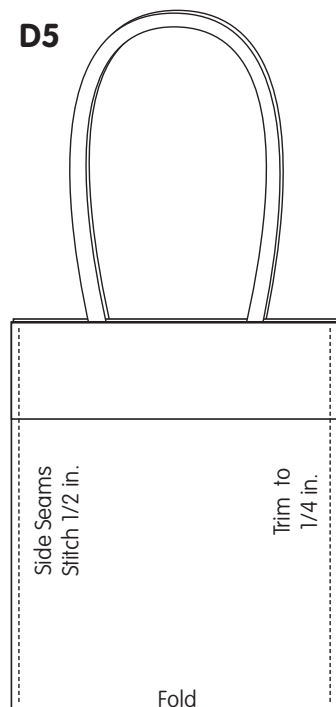

D6

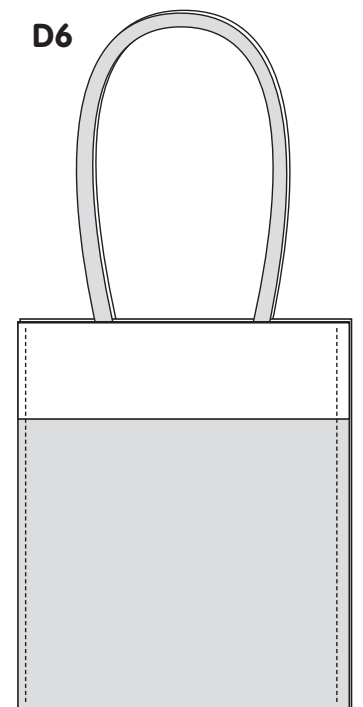

D7

